



**SCARICATORI DI TENSIONE
GAS TUBE ARRESTERS**

SANKŌSHA
sankosha corporation

Ceramic Arresters

The Ceramic Gas Tube Arresters manufactured by Sankosha Corporation provide protection for personnel, equipment and circuitry from the abnormally high transient voltages which can be caused by lightning or electromagnetic induction. The arresters are designed with defined surge limiting characteristics. When the abnormal voltage on a line reaches that defined level, sparkover (or breakdown) occurs within the gas tube arrester, the surge is redirected and people and equipment are protected.

Sankosha's Ceramic Arresters are very durable and extremely gastight. They have precise sparkover voltages and very high AC current withstand capability and impulse withstand capability. Different applications require different types of arresters and Sankosha provides arresters to meet every need. Arrester models vary both in dimension and in electrical characteristics and it is important that arresters be selected in accordance with the requirements of the particular application. While two electrode arresters have the advantage of being lower priced, the opening in the center electrode of the three electrode arrester allows the two gaps of the arrester to share a common gas chamber. This causes sparkover to occur almost simultaneously in both sides of the arrester and minimizes the current surge in the protected lines.

The various standard designs that Sankosha currently produces are described in this catalogue. Arresters for special applications are also available and we welcome your inquiries if the model you need is not listed here.

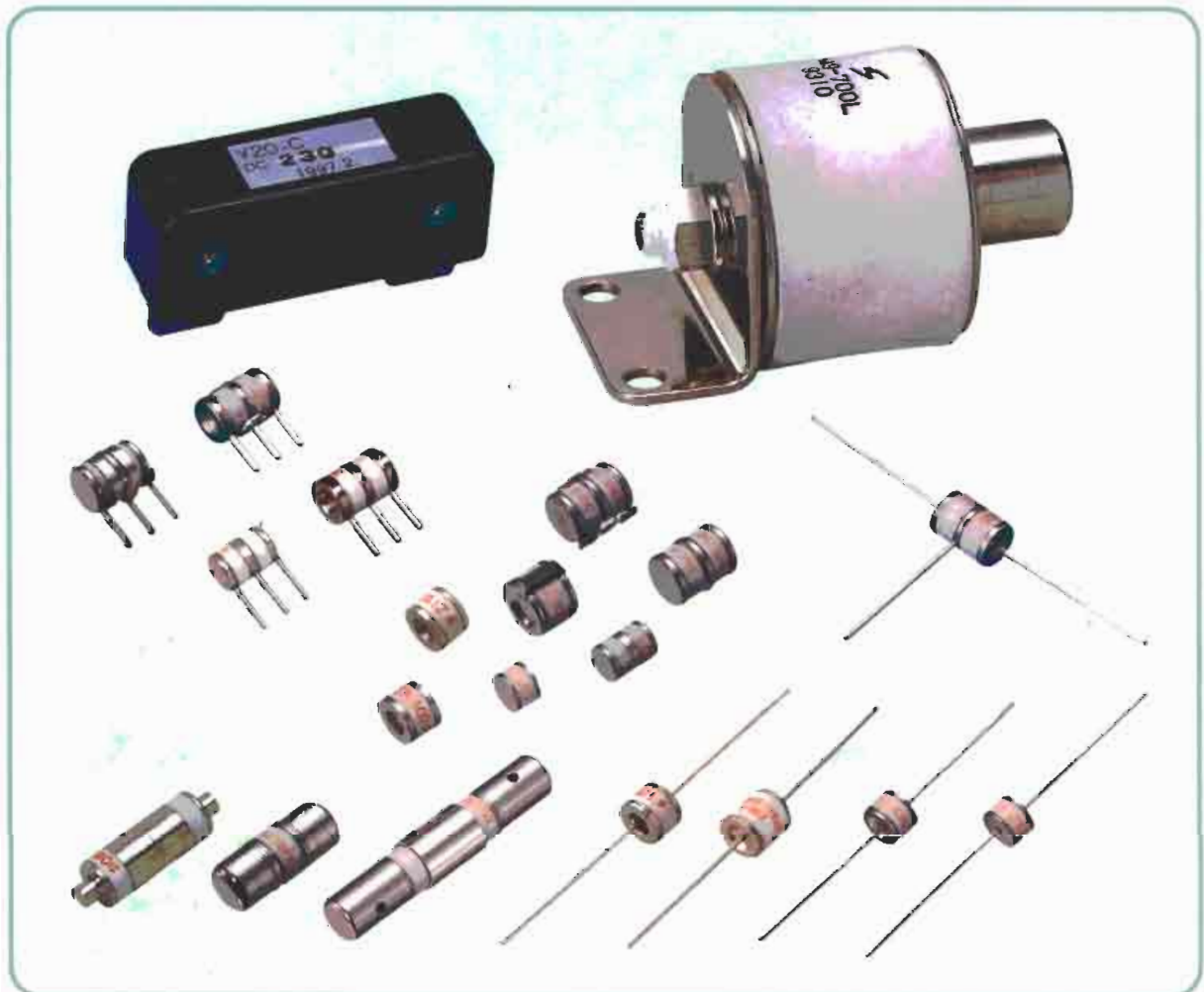

ISO 9001

SANKOSHA is the proud recipient of ISO-9001 Certification and controls the quality of all its products according to strictly established ISO-9001 standards.



100% Inspection

The DC Sparkover Voltage, Insulation Resistance and External Dimension characteristics of all Sankosha arresters (100% sampling) are tested during the production process. Other performance characteristics are checked with appropriate sampling procedures.

AQL Sampling

The scope of Sankosha's sampling inspections and the maximum admissible number of defects are based on the Single Sampling Plan for General Inspection - Level-I and the Normal Inspection Procedures as defined by ISO 2859. The AQL at delivery is 0.65 for the DC Sparkover Voltage and Insulation Resistance characteristics of our arresters.

Warranty

Sankosha warrants its products for a period of one year after installation or fifteen months after shipment from the factory, whichever comes first. If defective product claims are found to be justifiable, replacement products meeting the applicable specification will be provided in principle.

Radioactive Material Free

Sankosha's products contain no radioactive material.

Temperature Stress

■ Operation Temperature Range

Models without Fail-Safe Device: -30°C ~ 65°C

Models with Fail-Safe Device: -20°C ~ 65°C

■ Storage Temperature Range

Models without Fail-Safe Device: -30°C ~ 65°C

Models with Fail-Safe Device: -20°C ~ 65°C

Packaging

Sankosha's arresters are normally packed 100 pieces in a plastic tray or 200 pieces in a vacuum bag, ten trays or five bags (1,000 pieces) to a standard box.

Fail-Safe Device

Purpose

Gas Tube Arresters are typically used to quickly and safely protect modern telecommunications equipment from damage caused by transient surge voltages. Lightning and equipment switching operations are two common causes of these short duration surge voltages. Gas Tube Arrester operation does not generate any significant heat during these events which normally last a few microseconds or less.

However, surge voltages can also be caused by crossover from power supply lines and last significantly longer. Gas Tube Operation may continue for extended periods and generate significant thermal energy. To prevent heat caused damage to the arrester magazine or the terminal block and to eliminate any possible fire hazard, a Gas Tube Arrester equipped with back-up short circuit mechanism known as a Fail-Safe Device may be employed.

Operation

The Fail-Safe Device is a short circuit spring that is mounted on the center electrode of the Gas Tube Arrester. Prior to operation, a solder pellet installed between the spring and the center electrode of the Gas Tube Arrester and thin insulating tubes covering sharp projections at each end of the short circuit spring force the Fail-Safe Device to "float" 0.1-0.5 mm above the outer electrodes of the Gas Tube Arrester.

Before Operation

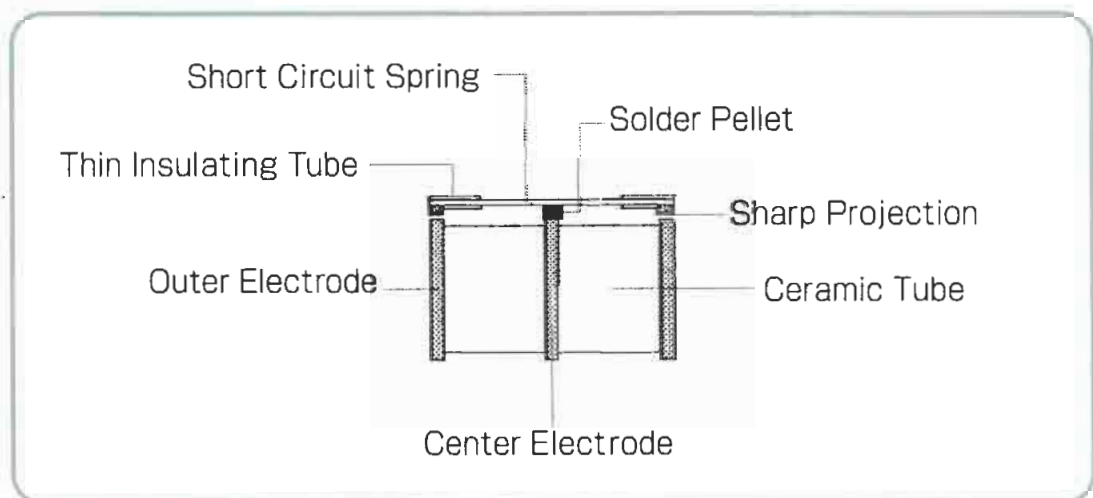

When prolonged discharge operation causes the temperature of the Gas Tube Arrester to rise to the melting point of the solder pellet, the short circuit spring moves closer to the Gas Tube Arrester and its tension forces the projections through the thin insulation making contact with both Gas Tube Arrester outer electrodes. This process permanently short-circuits all three electrodes creating a low resistance path to ground that will conduct the fault current without generating significant heat.

After Operation

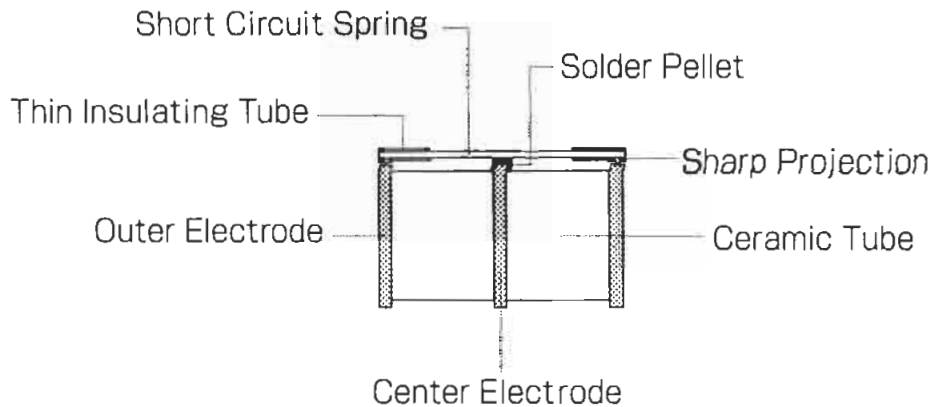

Fail-Safe Activation Time

Fail-Safe Device Activation Times vary from model to model. See the Gas Tube Arrester Specifications for details.

Installation

Care should be taken when installing Gas Tube Arresters equipped with Fail-Safe Devices into arrester magazines, printed circuit boards, etc. because too much downward pressure may force the short circuit spring projections through the thin insulation creating a shorted condition.

Fail-Safe Device Equipped Gas Tube Arrester Model Numbers

- Two Electrode Gas Tube Arresters with Fail-Safe Device
 - Y08JS-230AF1
 - Y08UZ-230AF1
- Three Electrode Gas Tube Arresters with Fail-Safe Device
 - 3YVJ-90J1F2
 - 3YVJ-145J1F2
 - 3YVJ-200J1F2
 - 3YVJ-230J1F2
 - 3YVJ-250J1F2
 - 3YVJ-260J1F2
 - 3YVJ-300J1F2
 - 3YVJ-350J1F2
 - 3YVJ-400J1F2
 - 3YVJ-550J1F2
 - 3YVH-230AF5
 - 3YVH-250AF5
 - 3YVH-350AF5
 - 3YVH-230J1F5

Standard Part Number Definitions

Two Electrode Arresters

■ Example: Part Number Y08UZ-230A

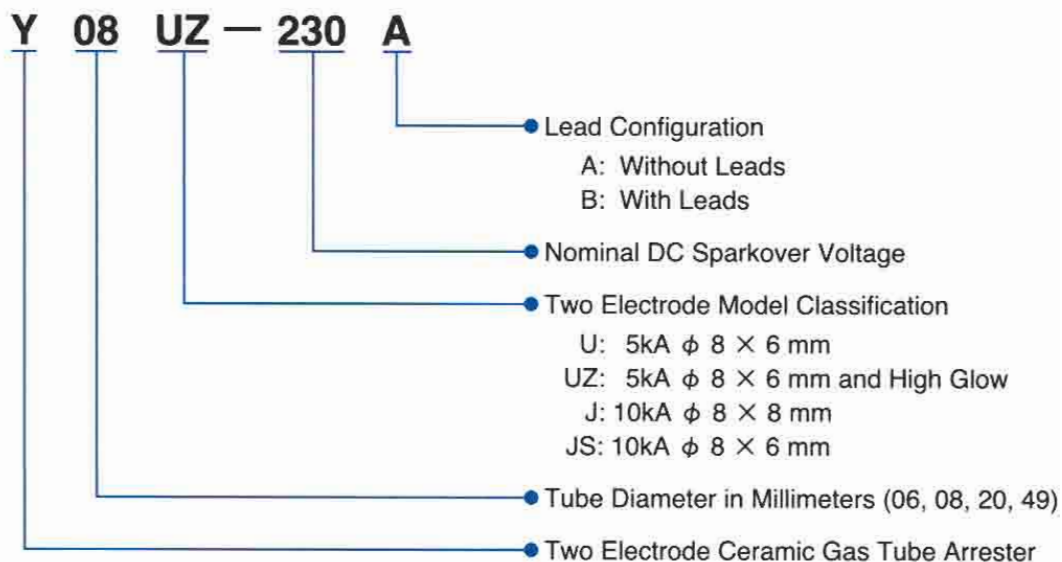

Three Electrode Arresters

■ Example: Part Number 3YVH-230J1F5

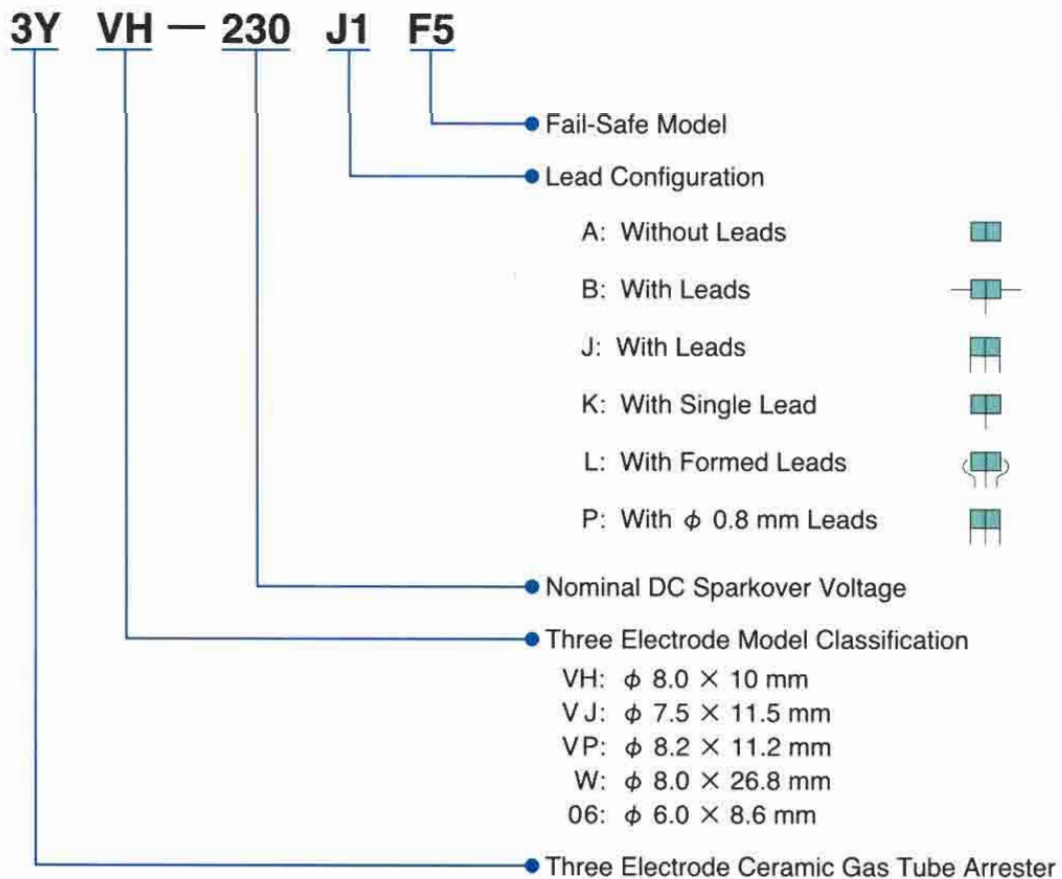

Two Electrode Arresters

Example: Part Number Y08UZ-230A

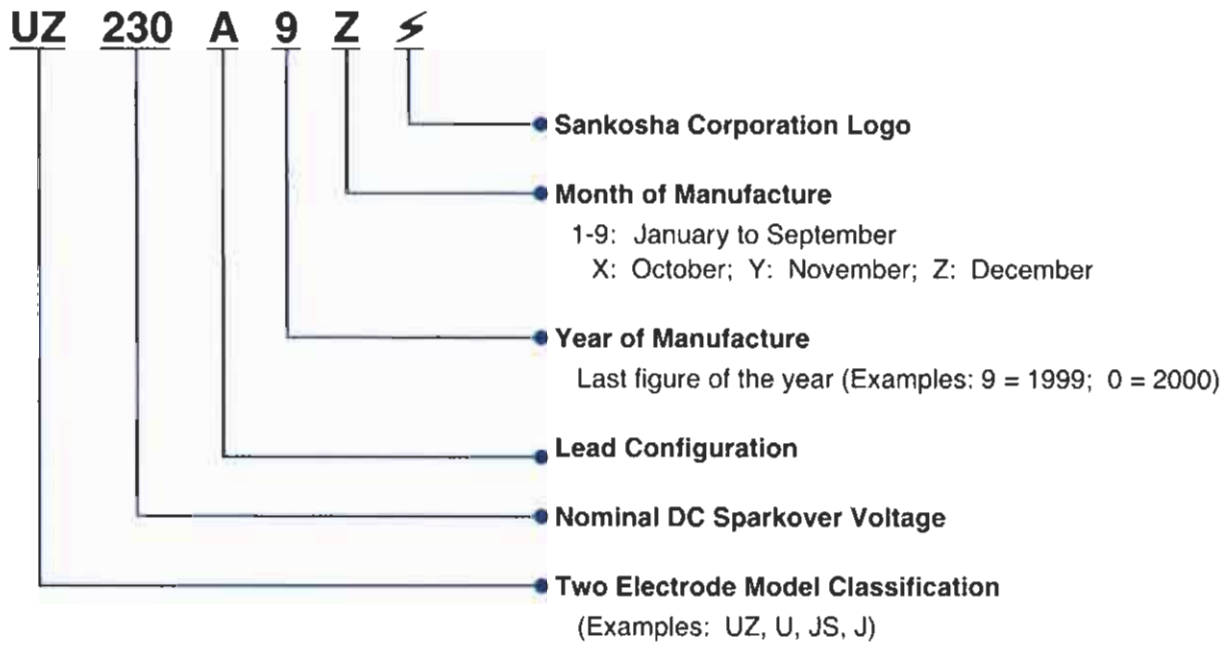

Three Electrode Arresters

Example: Part Number 3YVH-230J1F5

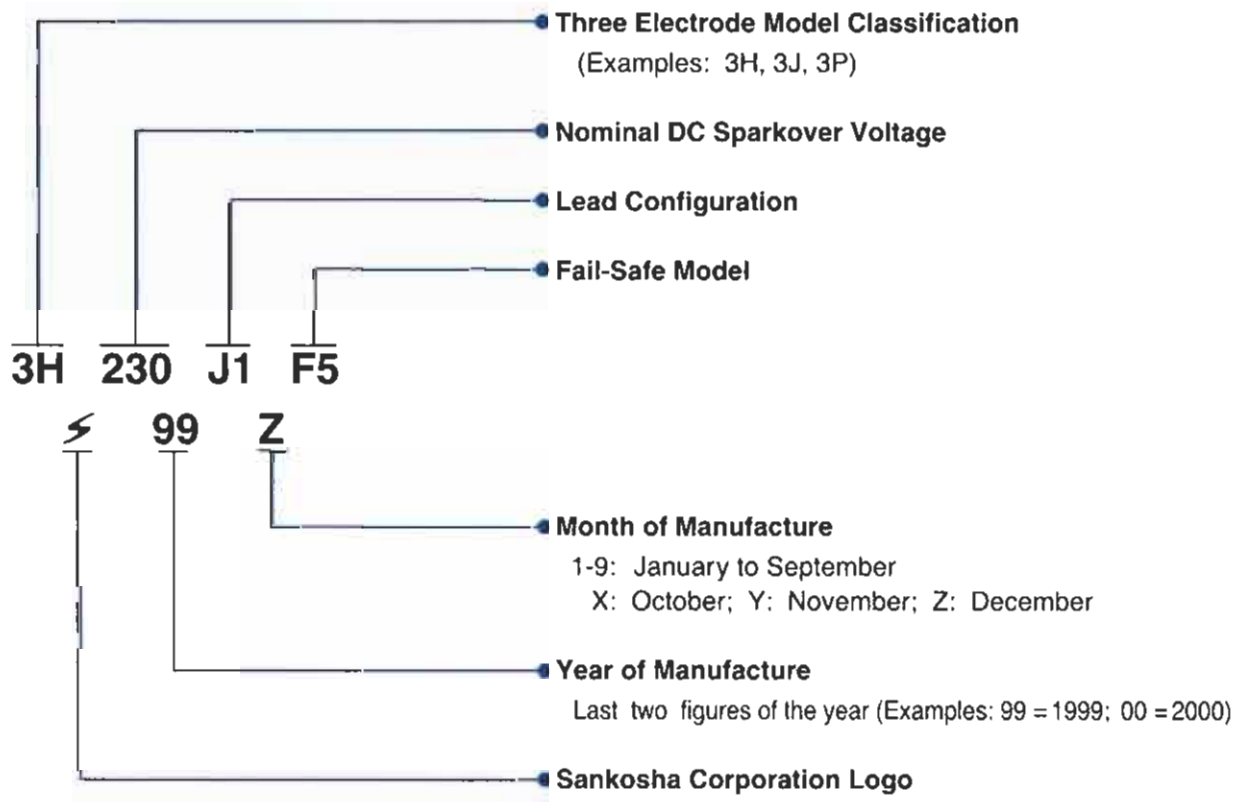

TERMINOLOGY

Unless otherwise specified, the terms used throughout this catalogue are defined as follows.

- DC Sparkover Voltage :** With a rate of rise of 100V/s or less, the minimum rising DC voltage that will cause sparkover or breakdown when applied across the terminals of an arrester.
- Impulse Sparkover Voltage :** The maximum voltage attained by an impulse of designated waveform (100 V/ μ s or 1 kV/ μ s) applied across the terminals of an arrester prior to the flow of discharge current.
- Insulation Resistance :** The resistance measured between the terminals of an arrester when the DC voltage specified in this catalogue is applied at a nominal ambient temperature (25°C) and relative humidity (75%).
- Capacitance :** The capacitance as measured between the terminals of an arrester.
- DC Holdover Voltage :** The maximum DC Voltage across the terminals of an arrester under which it may be expected to clear and return to its high impedance state after the passage of a surge under specified circuit conditions.
- Impulse Life :** The minimum number of impulses of a specified waveform and peak current which an arrester will conduct without suffering any of the failure judgment modes as defined in this catalogue.
- Impulse Discharge Current :** The maximum current of a waveform of 8/20 μ s that can be applied across the terminals of an arrester without causing the arrester to fail as defined by the failure judgment modes described below.
- AC Discharge Current :** The RMS current value that an arrester will conduct without suffering any of the failure judgment modes defined in this catalogue when a current of 50 Hz or 60 Hz is applied for a period of 9 cycles (50 Hz) or 11 cycles (60 Hz).
- Failure Judgment :** After the Impulse Life Test, Impulse Discharge Current Test and the AC Discharge Current Test, an arrester shall be judged to have failed if any of the following failure modes exists.
- | | |
|---------------------------------|---|
| Low DC Sparkover Voltage: | Less than 50% of the nominal DC Sparkover Voltage |
| High DC Sparkover Voltage: | More than 150% of the nominal DC Sparkover Voltage |
| High Impulse Sparkover Voltage: | More than 150% of the nominal 100V/ μ s Impulse Sparkover Voltage |
| Insulation Resistance: | Less than one Megohm |

Y08JS Series (Two Electrode)



Model A Fig.1

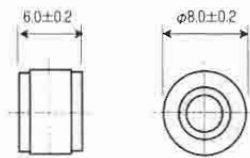

Body : Nickel Plated
Unit Weight : 1.5g

Units : mm



Model AF1 Fig.2

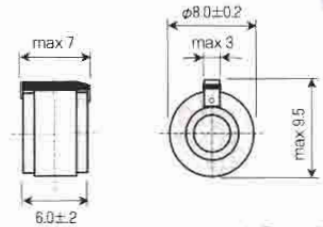

Body : Nickel Plated
Unit Weight : 1.5g

Units : mm

Model B Fig.3

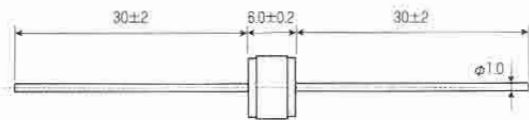

Electrodes : Nickel Plated
Leads : Tin Plated
Unit Weight : 1.9g

Units : mm



Note :

1. Insulation Resistance shall be measured with the following voltages for each nominal DC Sparkover Voltage.

Nominal DC Sparkover Voltage	Measuring Voltage
90~145V	DC 50V
230~350V	DC 100V

Model YX Fig.4

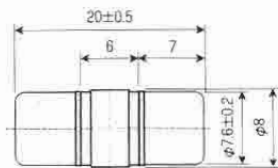

Electrodes : Nickel Plated
Leads : N/A
Unit Weight : 4.0g

Units : mm



2. DC Holdover Voltage shall be measured in accordance with the ITU-T K.12, Test Circuit or the IEEE C62.31-1987 Test Circuit.

3. Fail-Safe Operation Time
50Hz 0.7A : 210sec.
2.0A : 60sec.
7.0A : Instantaneous

4. Capacitance of Y08JS-230AF1 : ≤ 3.5pF

Part Number	Model A : Without leads	See Fig. 1	Y08JS-90A	Y08JS-145A	Y08JS-230A	Y08JS-250A	Y08JS-350A
	Model B : With leads	See Fig. 3	Y08JS-90B	Y08JS-145B	Y08JS-230B	Y08JS-250B	Y08JS-350B
	Model AF1 : With Fail-Safe (See Note 3)	See Fig. 2			Y08JS-230AF1		
	Model YX	See Fig. 4	Y08JS-90YX	Y08JS-145YX	Y08JS-230YX	Y08JS-250YX	Y08JS-350YX

DC Sparkover Voltage	100V/s	70 - 110V	115 - 175V	180 - 280V	200 - 300V	290 - 430V
Impulse Sparkover Voltage	100V/μs	≤ 700V	≤ 700V	≤ 700V	≤ 700V	≤ 700V
	1kV/μs	≤ 800V	≤ 800V	≤ 800V	≤ 800V	≤ 800V
Insulation Resistance	See Note 1	≥ 10,000MΩ	≥ 10,000MΩ	≥ 10,000MΩ	≥ 10,000MΩ	≥ 10,000MΩ
Capacitance	1MHz	≤ 1.5pF	≤ 1.5pF	≤ 1.5pF See Note 4	≤ 1.5pF	≤ 1.5pF
DC Holdover Voltage	See Note 2	≤ 52V	≤ 52V	≤ 52V	≤ 52V	≤ 52V
Impulse Life	10/1000 μs, 100A	300 times	300 times	300 times	300 times	300 times
Impulse Discharge Current, 8/20 μs	Single	20kA	20kA	20kA	20kA	20kA
	Repeat 10 times (5 times - each polarity)	15kA	15kA	15kA	15kA	15kA
AC Discharge Current, 50Hz	Single, 9 Cycles	90A	90A	90A	90A	90A
	Repeat 1 sec. 10 times	20A	20A	20A	20A	20A

Y08U and Y08UZ Series (Two Electrode)

U-Series (UL Approved)



Model A : Without Leads

Fig.1

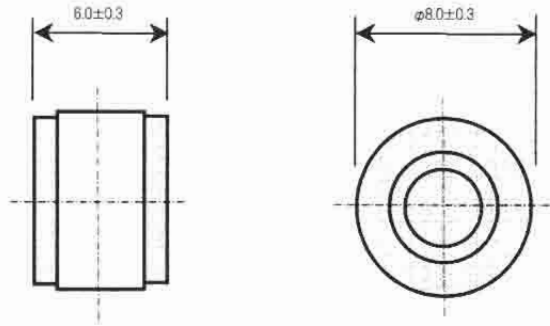

Body : Nickel Plated
Unit Weight : 1.3g

Units : mm

Part Number	Standard P/N	Model A :	Without leads	See Fig. 1	Y08U-75A	Y08U-90A	Y08UZ-145A
		Model B :	With leads	See Fig. 2	Y08U-75B	Y08U-90B	Y08UZ-145B
	UL Approved P/N See Note 3	Model A :	Without leads	See Fig. 1	U-1A	U-2A	U-3A
		Model B :	With leads	See Fig. 2	U-1B	U-2B	U-3B
DC Sparkover Voltage			100V/s	75V ± 20%	90V ± 20%	145V ± 15%	
Impulse Sparkover Voltage			100V/μs	≤ 500V	≤ 500V	≤ 500V	
			1kV/μs	≤ 700V	≤ 700V	≤ 700V	
Insulation Resistance			See Note 1	≥ 10,000MΩ	≥ 10,000MΩ	≥ 10,000MΩ	
Capacitance			1MHz	≤ 1.0pF	≤ 1.0pF	≤ 1.0pF	
DC Holdover Voltage			See Note 2	≤ 52V	≤ 52V	≤ 80V	
Impulse Life			10/1000 μs, 500A	300 times	300 times	300 times	
Impulse Discharge Current, 8/20 μs			Single	10kA	10kA	10kA	
			Repeat 10 times (5 times each polarity)	5kA	5kA	5kA	
AC Discharge Current, 50Hz			Single, 9 Cycles	65A	65A	65A	
			Repeat 1 sec.	10A, 5 times	10A, 5 times	10A, 5 times	

Y08U and Y08UZ Series (Two Electrode)

U-Series (UL Approved)

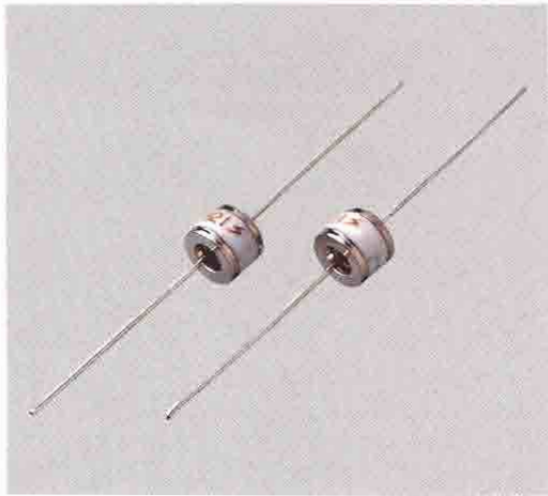

Model B : With Leads Fig.2

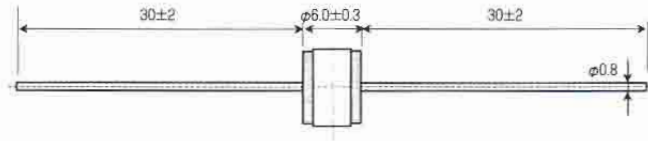

Electrodes : Nickel Plated
Leads : Tin Plated
Unit Weight : 1.6g

Units : mm

Note :

1. Insulation Resistance shall be measured with the following voltages for each nominal DC Sparkover Voltage.

Nominal DC Sparkover Voltage	Measuring Voltage
75~145V	DC 50V
230~400V	DC 100V
470~800V	DC 250V

2. DC Holdover Voltage shall be measured in accordance with the ITU-T K.12, Test Circuit or the IEEE C62.31-1987 Test Circuit.

3. Recognized under UL497B, File Number E140906.

Y08UZ-230A	Y08UZ-250A	Y08UZ-300A	Y08UZ-350A	Y08UZ-400A	Y08UZ-470A	Y08UZ-600A	Y08UZ-800A
Y08UZ-230B	Y08UZ-250B	Y08UZ-300B	Y08UZ-350B	Y08UZ-400B	Y08UZ-470B	Y08UZ-600B	Y08UZ-800B
U-4A	U-5A	U-6A	U-7A	U-8A	U-9A	U-10A	U-11A
U-4B	U-5B	U-6B	U-7B	U-8B	U-9B	U-10B	U-11B

230V ± 15%	250V ± 15%	300V ± 15%	350V ± 15%	400V ± 15%	470V ± 15%	600V ± 15%	800V ± 15%
≤ 600V	≤ 600V	≤ 700V	≤ 700V	≤ 700V	≤ 700V	≤ 800V	≤ 1,000V
≤ 750V	≤ 800V	≤ 850V	≤ 850V	≤ 850V	≤ 850V	≤ 1000V	≤ 1,200V
≥ 10,000MΩ	≥ 10,000MΩ	≥ 10,000MΩ	≥ 10,000MΩ	≥ 10,000MΩ	≥ 10,000MΩ	≥ 10,000MΩ	≥ 10,000MΩ
≤ 1.0pF	≤ 1.0pF	≤ 1.0pF	≤ 1.0pF	≤ 1.0pF	≤ 1.0pF	≤ 1.0pF	≤ 1.0pF
≤ 135V	≤ 135V	≤ 150V	≤ 150V	≤ 150V	≤ 150V	≤ 150V	≤ 150V
300 times	500 times	500 times	500 times	500 times	500 times	500 times	500 times
10kA	10kA	10kA	10kA	10kA	10kA	10kA	10kA
5kA	5kA	5kA	5kA	5kA	5kA	5kA	5kA
65A	65A	65A	65A	65A	65A	65A	65A
10A, 5 times	10A, 10 times	10A, 10 times	10A, 10 times	10A, 10 times	10A, 10 times	10A, 10 times	10A, 10 times

Y08 Series (Two Electrode)

YZ, Y Series (UL Approved)

Model B

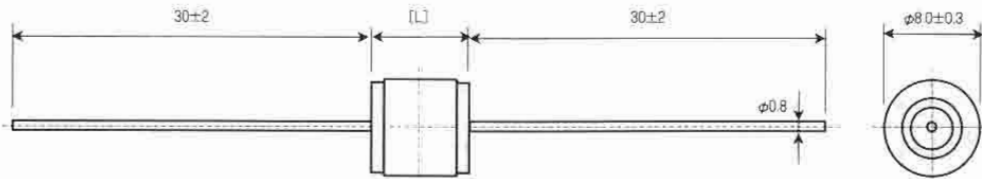
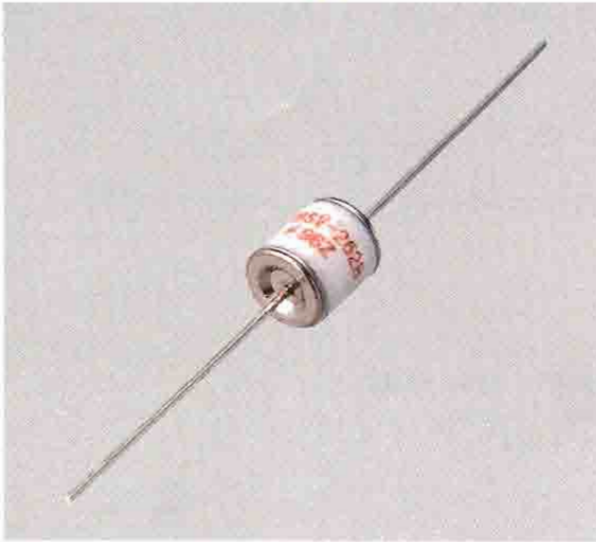

Body : Nickel Plated
Lead Wire : Tin Plated

Units : mm

Part Number	Model B : With Axial Leads See Figure 1	Standard P/N	Y08Z-102B	Y08-152B	Y08-212B
		UL Approved P/N See Notes 4 & 5	YZ-102B	Y-152B	Y-212B
		"L" in mm	8.0 ± 0.3	8.5 ± 0.3	8.5 ± 0.3
		Unit weight (g)	1.5	1.5	1.5
DC Sparkover Voltage	100V/s	1,000V ± 20%	1,500V ± 15%	2,100V ± 20%	
Impulse Sparkover Voltage	100V/μs	≤ 1,500V	≤ 2,200V	≤ 2,700V	
Insulation Resistance	See Note 1	≥ 10,000MΩ	≥ 10,000MΩ	≥ 10,000MΩ	
Capacitance	1MHz	1.0pF	≤ 1.0pF	≤ 1.0pF	
Impulse Life	10/1000 μs, 500A	200 times	10 times	10 times	
Impulse Discharge Current, 8/20 μs	Single	10kA	10kA	10kA	
	Repeat 10 times (5 times each polarity)	3kA	3kA	3kA	
AC Discharge Current, 50Hz	Single, 9 Cycles	5A	5A	5A	
	Repeat 1 sec. 10 times	1A	1A	1A	

Note :

1. Insulation Resistance shall be measured with the following voltages for each nominal DC Sparkover Voltage.

Nominal DC Sparkover Voltage	Measuring Voltage
1,000V	DC 250V
1,500~2,100V	DC 500V
2,400~6,000V	DC 1,000V

2. Measured with an 8/20 μ s, 100A impulse.

3. Repeat 10 times for each polarity.

4. All UL Approved Part Number Models are Recognized under **UL1449, File Number E96234**

5. **Y08SV-272B** is also Recognized under **UL1414, File Number E165829**.

Y08-242B	Y08-302B	Y08-402B	Y08-602B		
Y-242B	Y-302B	Y-402B	Y-602B	Y08SV-262B	Y08SV-272B
8.5±0.3	8.5±0.3	8.5±0.3	13.0±0.3	8.8±0.3	8.8±0.3
1.5	1.5	1.5	1.9	1.6	1.6
2,400V±20%	3,000V±20%	4,000V±20%	6,000V±20%	2,400 ~ 2,860V at 5kV/s	2,340 ~ 2,970V at 5kV/s
≤ 3,000V	≤ 4,000V	≤ 5,000V	≤ 8,000V	≤ 3,700V	≤ 3,700V
≥ 10,000MΩ	≥ 10,000MΩ	≥ 10,000MΩ	≥ 10,000MΩ	≥ 100MΩ	≥ 100MΩ
≤ 1.0pF	≤ 1.0pF	≤ 1.0pF	≤ 1.0pF	≤ 1.0pF	≤ 1.0pF
10 times	10 times	10 times	10 times	300 times See Note 2	300 times See Note 2
10kA	10kA	10kA	10kA	N/A	N/A
3kA	1kA	1kA	1kA	3kA See Note 3	3kA See Note 3
5A	5A	5A	5A	N/A	N/A
1A	1A	1A	1A	N/A	N/A

Note :

1. Insulation Resistance shall be measured with the following voltages for each nominal DC Sparkover Voltage.

Nominal DC Sparkover Voltage	Measuring Voltage
1,000V	DC 250V
1,500~2,100V	DC 500V
2,400~6,000V	DC 1,000V

2. Measured with an 8/20 μ s, 100A impulse.

3. Repeat 10 times for each polarity.

4. All UL Approved Part Number Models are Recognized under **UL1449, File Number E96234**

5. **Y08SV-272B** is also Recognized under **UL1414, File Number E165829**.

Y08-242B	Y08-302B	Y08-402B	Y08-602B		
Y-242B	Y-302B	Y-402B	Y-602B	Y08SV-262B	Y08SV-272B
8.5±0.3	8.5±0.3	8.5±0.3	13.0±0.3	8.8±0.3	8.8±0.3
1.5	1.5	1.5	1.9	1.6	1.6

2,400V±20%	3,000V±20%	4,000V±20%	6,000V±20%	2,400 ~ 2,860V at 5kV/s	2,340 ~ 2,970V at 5kV/s
≤ 3,000V	≤ 4,000V	≤ 5,000V	≤ 8,000V	≤ 3,700V	≤ 3,700V
≥ 10,000MΩ	≥ 10,000MΩ	≥ 10,000MΩ	≥ 10,000MΩ	≥ 100MΩ	≥ 100MΩ
≤ 1.0pF	≤ 1.0pF	≤ 1.0pF	≤ 1.0pF	≤ 1.0pF	≤ 1.0pF
10 times	10 times	10 times	10 times	300 times See Note 2	300 times See Note 2
10kA	10kA	10kA	10kA	N/A	N/A
3kA	1kA	1kA	1kA	3kA See Note 3	3kA See Note 3
5A	5A	5A	5A	N/A	N/A
1A	1A	1A	1A	N/A	N/A

3YVJ Series (Three Electrode)

3J Series (UL Approved)

Symbol

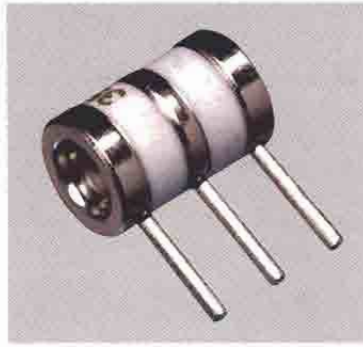
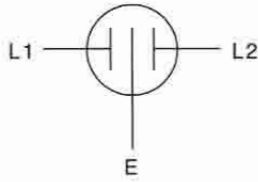

Model J1

Fig.1

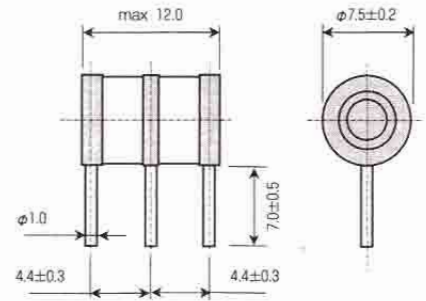

Electrodes : Nickel Plated
Leads : Tin Plated
Unit Weight : 2.8g

Units : mm

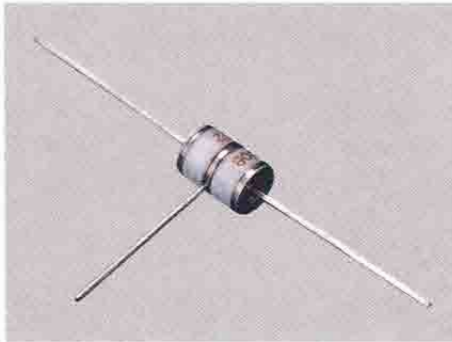

Model B

Fig.2

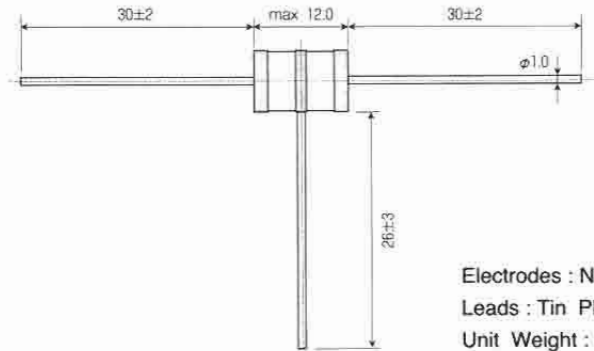

Electrodes : Nickel Plated
Leads : Tin Plated
Unit Weight : 2.8g

Units : mm

Part Number	Standard Part Number	Lead configuration : J1	See Fig. 1		3YVJ-90J1	3YVJ-145J1
		Fail-Safe Model : J1F2	See Fig. 3	With Fail-Safe (See Note 4)	3YVJ-90J1F2	3YVJ-145J1F2
		Lead configuration : B	See Fig. 2		3YVJ-90B	3YVJ-145B
	UL Approved Part Number (See Note 3)	Lead configuration : B	See Fig. 2		3J-1B	3J-2B
		Lead configuration : J1	See Fig. 1		3J-1J1	3J-2J1

DC Sparkover Voltage (L1-E)(L2-E)	100V/s	90V ± 20%	145V ± 20%
Impulse Sparkover Voltage (L1-E)(L2-E)	100V/μs	≤ 700V	≤ 700V
	1kV/μs	≤ 850V	≤ 850V
Insulation Resistance	See Note 1	≥ 10,000MΩ	≥ 10,000MΩ
Capacitance	1MHz	≤ 3.0pF	≤ 3.0pF
DC Holdover Voltage	See Note 2	≤ 52V	≤ 52V
Impulse Life (L1+L2-E)	10/1000 μs, 400A	300 times	300 times
Impulse Discharge Current, 8/20 μs (L1+L2-E)	Single	20kA	20kA
	Repeat 10 times (5 times each polarity)	10kA	10kA
AC Discharge Current, 50Hz (L1+L2-E)	Single (9 Cycles)	130A	130A
	Repeat 10 times (1 second)	10A	10A

3YVJ Series (Three Electrode)

3J Series (UL Approved)



Fail-Safe Model J1F2 Fig.3

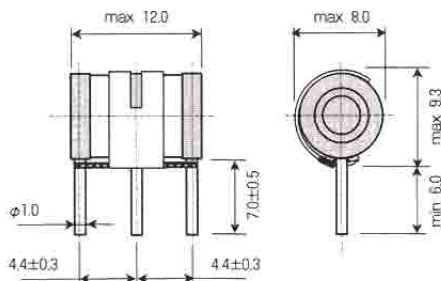

Electrodes : Nickel Plated
Leads : Tin Plated
Unit Weight : 2.8g

Units : mm

Note :

1. Insulation Resistance shall be measured with the following voltages for each nominal DC Sparkover Voltage.

Nominal DC Sparkover Voltage	Measuring Voltage
90V~145V	DC 50V
200~550V	DC 100V

2. DC Holdover Voltage shall be measured in accordance with the ITU-T K.12, Test Circuit or the IEEE C62.31 1987 Test Circuit.

3. Recognized under UL497B, File Number E14096.

4. Fail-Safe Operation Time : at 25°C for Fail-Safe Model F2
(Other Fail-Safe models are available)

L1+L2-E

1A+1A :	≤	15 sec
3A+3A :	≤	10 sec
5A+5A :	≤	7 sec
10A+10A :	≤	5 sec

5. Measured with impulse waveform : 10/1000μs, 1000A

6. Lead spacings(pitch) of 4.7 mm and 5.0 mm are available by request.

	3YVJ-230J1		3YVJ-260J1	3YVJ-300J1	3YVJ-350J1	3YVJ-400J1	3YVJ-550J1
3YVJ-200J1F2	3YVJ-230J1F2	3YVJ-250J1F2	3YVJ-260J1F2	3YVJ-300J1F2	3YVJ-350J1F2	3YVJ-400J1F2	3YVJ-550J1F2
	3YVJ-230B	3YVJ-250B	3YVJ-260B	3YVJ-300B	3YVJ-350B	3YVJ-400B	
	3J-3B	3J-4B		3J-5B	3J-6B	3J-7B	
	3J-3J1	3J-4J1		3J-5J1	3J-6J1	3J-7J1	

200V ± 25%	230V ± 20%	250V ± 20%	260V ± 20%	300V ± 20%	350V ± 20%	400V ± 20%	550V ± 20%
≤ 500V	≤ 500V	≤ 500V	≤ 500V	≤ 600V	≤ 600V	≤ 700V	≤ 850V
≤ 650V	≤ 650V	≤ 650V	≤ 650V	≤ 750V	≤ 750V	≤ 850V	≤ 1,000V
≥ 10,000MΩ	≥ 10,000MΩ	≥ 10,000MΩ	≥ 10,000MΩ	≥ 10,000MΩ	≥ 10,000MΩ	≥ 10,000MΩ	≥ 10,000MΩ
≤ 3.0pF	≤ 3.0pF	≤ 3.0pF	≤ 3.0pF	≤ 3.0pF	≤ 3.0pF	≤ 3.0pF	≤ 3.0pF
≤ 135V	≤ 135V	≤ 135V	≤ 135V	≤ 135V	≤ 150V	≤ 150V	≤ 150V
300 times	300 times	300 times	300 times	300 times	300 times	400 times (See Note 5)	300 times
20kA	20kA	20kA	20kA	20kA	20kA	20kA	20kA
10kA	10kA	10kA	10kA	10kA	10kA	10kA	10kA
130A	130A	130A	130A	130A	130A	130A	130A
10A	10A	10A	10A	10A	10A	10A	10A

3YVH Series (Three Electrode)

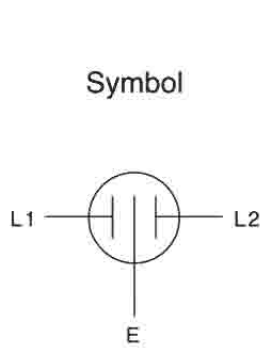
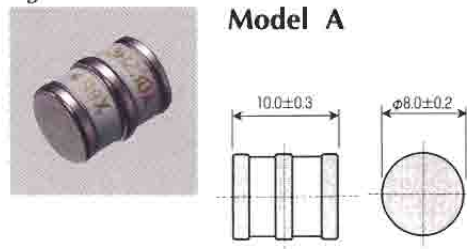

Fig.1



Model A

Electrodes : Nickel Plated
Unit Weight : 2.45g

Units : mm

Fig.2

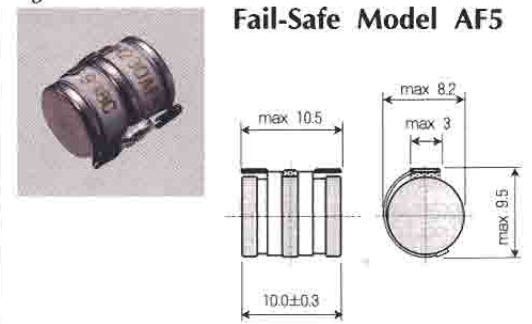

Fail-Safe Model AF5

Electrodes : Nickel Plated
Unit Weight : 2.6g

Units : mm

Fig.3



Fail-Safe Model J1F5

Electrodes : Nickel Plated
Leads : Nickel Plated
Unit Weight : 2.75g

Units : mm

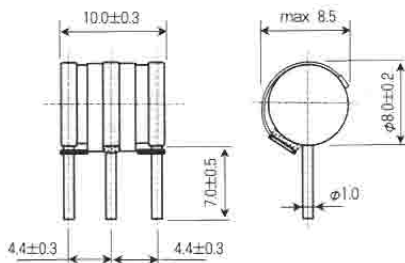

Note :

- DC Holdover Voltage measurement shall comply with ITU-T K.12, Test #3 for 3YVH-230 & 3YVH-250, and Test #2 for 3YVH-350.
- Fail-Safe Operation Time : 10 sec at AC 10A(5A+5A=L1+L2)
- Measured Impulse : 100A(5A+5A=L1+L2)
 - After Impulse Life, Impulse & AC Discharge Current Test
DC Sparkover Voltage : 180~300V
Impulse Sparkover Voltage : ≤ 900V
Insulation Resistance : ≥ 100MΩ
 - After Impulse Life, Impulse & AC Discharge Current Test
DC Sparkover Voltage : 250V±50%
Impulse Sparkover Voltage : ≤ 900V
Insulation Resistance : ≥ 100MΩ
 - After Impulse Life, Impulse & AC Discharge Current Test
DC Sparkover Voltage : 250~450V
Impulse Sparkover Voltage : ≤ 900V
Insulation Resistance : ≥ 100MΩ

Part Number	Model A :	Without leads	See Fig. 1	3YVH-230A	3YVH-250A	3YVH-350A
	Model AF5 :	With Fail-Safe (See Note 2)	See Fig. 2	3YVH-230AF5	3YVH-250AF5	3YVH-350AF5
	Model J1F5 :	With leads and Fail-Safe	See Fig. 3	3YVH-230J1F5		

DC Sparkover Voltage (L1-E)(L2-E)	100V/s	180 - 300V	200 - 300V	280 - 420V
Impulse Sparkover Voltage (L1-E)(L2-E)	1kV/μs	≤ 900V	≤ 900V	≤ 900V
Insulation Resistance	100V DC	≥ 1,000MΩ	≥ 1,000MΩ	≥ 1,000MΩ
Capacitance	1MHz	≤ 3.0pF	≤ 3.0pF	≤ 3.0pF
DC Holdover Voltage	See Note 1	≤135V	≤135V	≤ 80V
Impulse Life (L1+L2-E)	10/1000 μs 200A	300 times See Note 3A	300 times See Note 3B	300 times See Note 3C
Impulse Discharge Current, 8/20 μs (L1+L2-E)	Repeat 10 times (5 times, each polarity)	Not specified	Not specified	20kA See Note 3C
AC Discharge Current, 50Hz (L1+L2-E)	Repeat 5 times 1 sec.	10A See Note 3A	20A See Note 3B	20A See Note 3C

3YW Series (Three Electrode)

Symbol

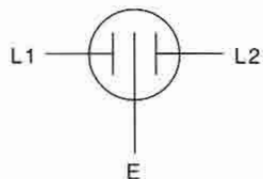

Model A

Fig.1

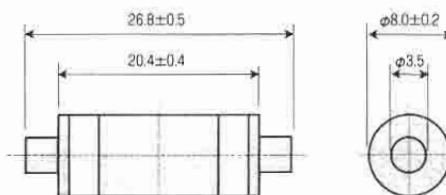

Electrodes : Nickel Plated

Unit Weight : 5.7g

Units : mm

Model YZ Fig.2



Electrodes : Nickel Plated

Unit Weight : 9.3g

Units : mm

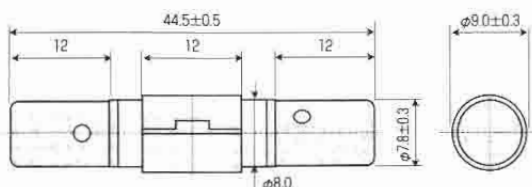

Note :

1. Insulation Resistance shall be measured with the following voltages for each nominal DC Sparkover Voltage.

Nominal DC Sparkover Voltage	Measuring Voltage
90V	DC 50V
230~400V	DC 100V

2. DC Holdover Voltage shall be measured in accordance with the ITU-T K.12, Test Circuit or the IEEE C62.31-1987 Test Circuit.

Part Number	See Figure 1	3YW-90A	3YW-230A	3YW-350A	3YW-400A
	See Figure 2	3YW-90YZ	3YW-230YZ	3YW-350YZ	3YW-400YZ
DC Sparkover Voltage (L1-E)(L2-E)	100V/s	90V±20%	230V±20%	350V±20%	400V±25%
Impulse Sparkover Voltage (L1-E)(L2-E)	100V/μs	≤ 500V	≤ 600V	≤ 650V	≤ 700V
	1kV/μs	≤ 700V	≤ 800V	≤ 850V	≤ 900V
Insulation Resistance	See Note 1	≥ 10,000MΩ	≥ 10,000MΩ	≥ 10,000MΩ	≥ 10,000MΩ
Capacitance	1MHz	≤ 3.0pF	≤ 3.0pF	≤ 3.0pF	≤ 3.0pF
DC Holdover Voltage	See Note 2	≤ 52V	≤ 150V	≤ 150V	≤ 150V
Impulse Life (L1+L2-E)	10/1000 μs 1000A	1,000 times	1,000 times	1,000 times	1,000 times
Impulse Discharge Current 8/20 μs (L1+L2-E)	Single	40kA	40kA	40kA	40kA
	Repeat 10 times (5 times, each polarity)	20kA	20kA	20kA	20kA
AC Discharge Current 50Hz (L1+L2-E)	Single (9 cycles)	400A	400A	400A	400A
	Repeat 10 times (1 second)	20A	20A	20A	20A

Y06S Series (Miniature Two Electrode)



Model A *Fig.1*

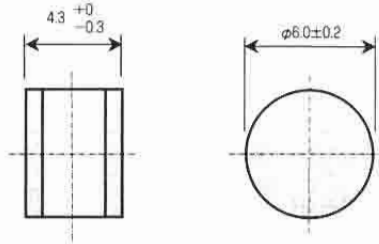

Electrodes : Nickel Plated
Unit Weight : 0.6g

Units : mm

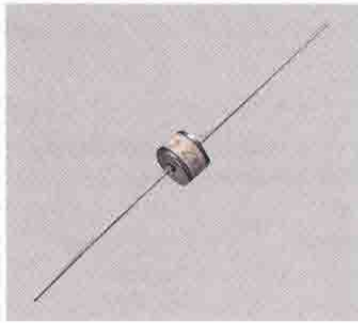

Model B *Fig.2*

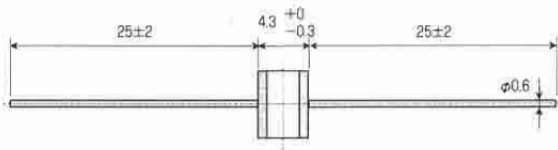

Electrodes : Nickel Plated
Leads : Tin Plated
Unit Weight : 0.7g

Units : mm

Note :

1. Insulation Resistance shall be measured with the following voltages for each nominal DC Sparkover Voltage.

Nominal DC Sparkover Voltage	Measuring Voltage
100V	DC 50V
230~350V	DC 100V

2. DC Holdover Voltage shall be measured in accordance with the ITU-T K.12, Test Circuit or the IEEE C62.31-1987 Test Circuit.

Part Number	Model A : Without leads	See Fig. 1	Y06S-100A	Y06SZ-230A	Y06SZ-350A
	Model B : With leads	See Fig. 2	Y06S-100B	Y06SZ-230B	Y06SZ-350B
DC Sparkover Voltage	100V/s	100V ± 20%	230V ± 20%	350 ± 20%	
Impulse Sparkover Voltage	100V/μs	≤ 500V	≤ 500V	≤ 600V	
	1kV/μs	≤ 700V	≤ 700V	≤ 800V	
Insulation Resistance	See Note 1	≥ 10,000MΩ	≥ 10,000MΩ	≥ 10,000MΩ	
Capacitance	1MHz	≤ 1.0pF	≤ 1.0pF	≤ 1.0pF	
DC Holdover Voltage	See Note 2	≤ 52V	≤ 135V	≤ 135V	
Impulse Life	10/1000 μs, 100A	200 times	200 times	200 times	
Impulse Discharge Current, 8/20 μs	Single	3kA	N/A	N/A	
	Repeat 10 times (5 times, each polarity)	N/A	5kA	5kA	
AC Discharge Current, 50Hz	Single, 9 Cycles	20A	20A	20A	
	Repeat 1 sec. 10 times	N/A	5A	5A	

3Y06 Series (Miniature Three Electrode)

Symbol

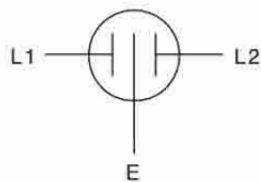

Model A

Fig.1

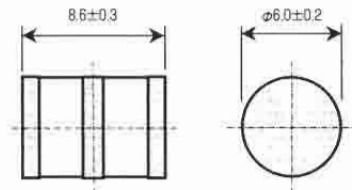

Electrodes : Nickel Plated
(Tin Plated are available by request)

Unit Weight : 1.3g

Units : mm



Model P1

Fig.2

Electrodes : Nickel Plated

Leads : Tin Plated

Unit Weight : 1.4g

Units : mm

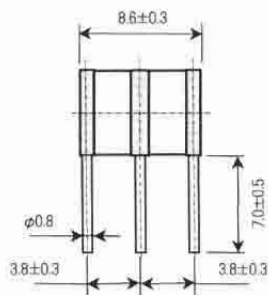

Note :

1. Insulation Resistance shall be measured with the following voltages for each nominal DC Sparkover Voltage.

Nominal DC Sparkover Voltage	Measuring Voltage
90V	DC 50V
230~350V	DC 100V

2. DC Holdover Voltage measurement shall comply with ITU-T K.12.

3. After Impulse Life, Impulse & AC Discharge Current Test.

- A. DC Sparkover Voltage : 90V±50%
- Impulse Sparkover Voltage : ≤ 900V
- Insulation Resistance : ≥ 100MΩ
- B. DC Sparkover Voltage : 180~300V
- Impulse Sparkover Voltage : ≤ 900V
- Insulation Resistance : ≥ 100MΩ
- C. DC Sparkover Voltage : 350V±50%
- Impulse Sparkover Voltage : ≤ 900V
- Insulation Resistance : ≥ 100MΩ

Part Number	Model A : Without leads	See Fig. 1	3Y06-90A	3Y06-230A	3Y06-350A
	Model P1 : With leads	See Fig. 2	3Y06-90P1	3Y06-230P1	3Y06-350P1
DC Sparkover Voltage (L1-E)(L2-E)	100V/s	90V±20%	230V±20%	350V±20%	
Impulse Sparkover Voltage (L1-E)(L2-E)	1kV/μs	≤ 850V	≤ 700V	≤ 750V	
Insulation Resistance	See Note 1	≥ 10,000MΩ	≥ 10,000MΩ	≥ 10,000MΩ	
Capacitance	1MHz	≤ 3.0 pF	≤ 3.0 pF	≤ 3.0 pF	
DC Holdover Voltage	See Note 2	≤ 52V	≤ 135V	≤ 150V	
Impulse Life (L1+L2-E)	10/1000 μs 200A	100 times See Note 3A	100 times See Note 3B	100 times See Note 3C	
Impulse Discharge Current, 8/20 μs (L1+L2-E)	Repeat 10 times (5 times, each polarity)	5kA See Note 3A	10kA See Note 3B	5kA See Note 3C	
AC Discharge Current, 50Hz (L1+L2-E)	Repeat 5 times 1 sec.	5A See Note 3A	10A See Note 3B	5A See Note 3C	



ESPERIENZA E INNOVAZIONE, DAL 1943.

FITRE COMPONENTI • Divisione della FITRE S.p.A.

20142 Milano – via Valsolda, 15 – telefono: 02.8959.0214 – telefax: 02.8959.0440

e-mail: fitre.componenti@fitre.it – internet <http://www.fitre.it>

Filiali a Roma e Venezia-Mestre

