

CB (Central Battery) and LB (Local Battery) phones
P/N 7131200

Weatherproof and vandal-proof analog LB (Local Battery) telephone

- Die-cast "copper-free" aluminium alloy case (suitable for petrochemical environments)
- 3x LR20, 1,5V, 60xØ34mm, type "D" batteries required (not included)
- 1x programmable memory key with 1x relevant light (red)
- Equipped with electronic ringer current generator
- Adjustable ringtone volume (max. 95dB/1m)
- INOX armored handset cable

-- Note --

If necessary, an additional external ringer such as the TRILLO 201T/E (P/N 7322255) can be connected to the telephone.

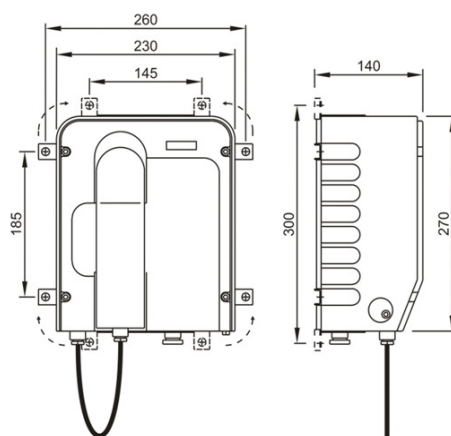
HANDSET
WALL MOUNTING
IP66
- 20°C to + 70°C

dimensions (W x H x D) 230,0 x 270,0 x 140,0 mm
weight 5,9 kg
