

**FITRE S.p.A. • Divisione DSI**

20142 Milano • Italia • via Valsolda, 15  
 telefono: (+39) 02.8959.01 • telefax: (+39) 02.8959.0400  
 e-mail: [divisione.dsi@fitre.it](mailto:divisione.dsi@fitre.it)

### TCS22AD CB Version without keypad

**Emergency telephone - connects directly to the main PABX.**

- ▶ **Robust explosion-proof, weatherproof telephone set, IP66**
- ▶ **ATEX certificated**

#### AREAS OF USE

Communication devices for use in hazardous areas in the industry have to be especially well adapted to the extreme operating conditions they will be exposed to.

Our new Ex-telephone has been developed for operation in the petrochemical industry, on off-shore plants, in mills and harbours, which means it is resistant to large temperature differences, air humidity, sea water, dust and strong mechanical wear and tear.

It is certified for use in hazardous dust and gas atmospheres.

#### TECHNICAL DATA

##### Connections

Types of protection .....	Ex II 2 G Ex eb mb [ib] IIC T6/T5 Gb II 2 D Ex tb [ib] IIIC T80°C/T100°C Db -25°C ≤ Ta ≤ +40°C / -25°C ≤ Ta ≤ +60°C
Approval .....	BVS 03 ATEX E 421 - CE 0158
Line voltage .....	24VDC + 66VDC
Line current .....	15mADC + 100mADC
Ringing alternating current .....	24VAC + 90VAC (at 21...54Hz ringing frequency)
.....	30VAC + 90VAC (at 16,6...54Hz ringing frequency)
Ringing impedance .....	Greater than 6,0 K at 25Hz and 24...90VAC Greater than 4,0 K at 50Hz and 24...90VAC
Inquiry key .....	Flash function adjustable from 40ms to 399ms
W-conductor .....	Connection for external secondary sounder
Screw terminals .....	Up to 4 mm <sup>2</sup> rigid. Up to 2.5 mm <sup>2</sup> flexible

##### Housing

Material .....	Glass-fibre-reinforced polyester
Height x Width x Depth .....	Approx. 266mm x 227mm x 135mm
Weight .....	Approx. 5.5kg

##### Receiver

Stabilizer bracket .....	Integrated, adjustable stabilizer bracket
Handset cord .....	Stainless steel (V4A) armoured handset cord
Receiver inset .....	Dynamic receiver inset with leakage field spool for inductive coupling of hearing aids
Mouthpiece .....	Electret-foil microphone
Noise suppression .....	Greater than 3dB due to integrated mouthpiece horn mouth

##### Environmental conditions

Degree of protection .....	IP 66 according to EN60529
Impact protection .....	IK 09 according to EN50102
Operation temperature .....	-25°C + +60°C for temperature class T5 -25°C + +40°C for temperature class T6
Storage temperature .....	-25°C + +70°C



#### MAIN PERFORMANCE DATA

- IP66 protection
- Impact protection IK 09
- Operations temperature -25°C to +60°C
- Stainless steel (V4A) keypad
- Steel armoured handset cord with snap-protection
- Sound pressure level approx. 90 dB(A)
- Integrated adjustable stabilizer bracket
- Connections for external loudspeaker

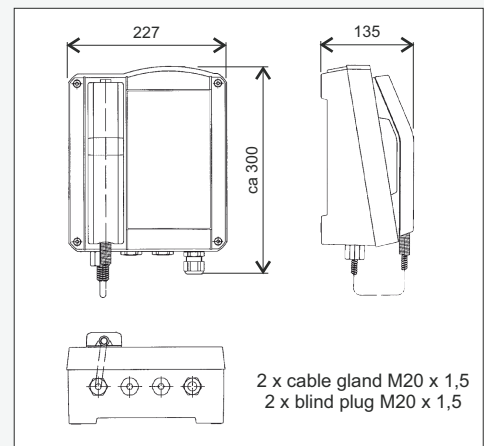

Model list	Type	P/N
CB Explosion-proof telephone	TCS22AD	7138170