

Vandal-proof, weatherproof and explosion-proof handsfree full-duplex phones (analog & VoIP)
P/N 7132712

Weatherproof analog ACB telephone for wall mount installation

HIGHLIGHTS

- IP65 GRP housing
- Handsfree
- Full-duplex conversation
- 1x large mushroom SOS pushbutton
- 1x status LED
- Colour: orange (RAL2004)

OPTIONAL CARDS

The telephone can be equipped with one of the following 2 optional cards:

- P/N 7133676: electronic card equipped with 2 relays to open door locks, to switch on/off lights, etc., suitable for being locally or remotely controlled through programmable DTMF codes.
- P/N 7133644: electronic card equipped with a booster amplifier suitable for being locally or remotely controlled through programmable DTMF codes. It can be used both for increasing the output volume of the integrated telephone loudspeaker and for connecting an external loudspeaker.

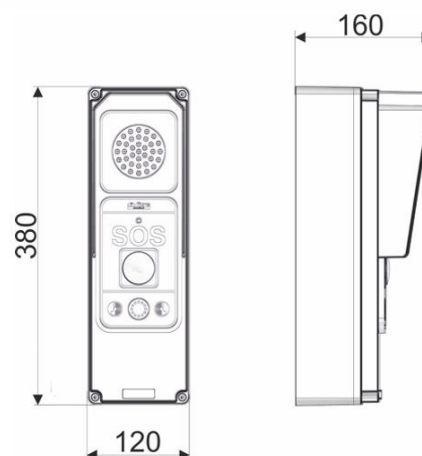
HANDSFREE
WALL MOUNTING
IP65
0°C to + 45°C
**Option:
Remote Monitoring by ASTRO System Manager**

dimensions (W x H x D) 120,0 x 380,0 x 160,0 mm
weight 2,4 kg

