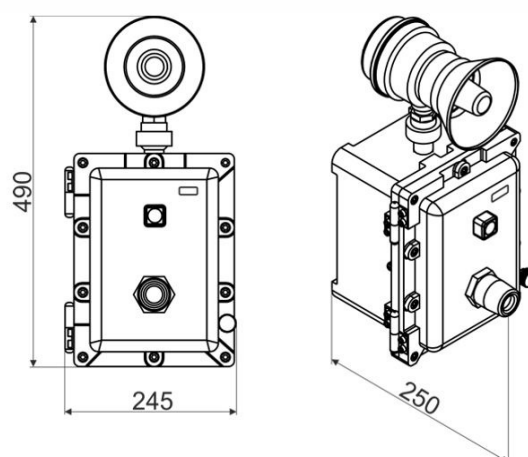

**Vandal-proof, weatherproof and explosion-proof handsfree full-duplex phones (analog & VoIP)**
**P/N 7133201**

Explosion-proof analog ACB telephone

- Light alloy oven-varnished housing
- ATEX Eex d IIB 2G T4
- Full-duplex handsfree
- 1x large programmable memory button
- 1x built-in relay
- Sound level of the call: >80dB/1m
- Auto hang-up at the end of conversation on detection of the busy tone
- Possibility of 12VDC power supply for a higher audio quality
- 2x 1/2" cable entries
- RAL7034 colour

**HANDSFREE**
**WALL MOUNTING**
**IP66**
**ATEX**
**- 20°C to + 70°C**

**dimensions (W x H x D) 245,0 x 490,0 x 250,0 mm**
**weight 12,6 kg**
