

FITRE S.p.A. • Divisione DSI

20142 Milano • Italia • via Valsolda, 15
 telefono: (+39) 02.8959.01 • telefax: (+39) 02.8959.0400
 e-mail: info@fitre.it

AC8425/0906

Telephone for indoor and outdoor use with protection door

- ▶ Protection degree IP 66 acc.to. IEC 60529
- ▶ Ambient temperature -25°C up to +55°C
- ▶ Protection door
- ▶ PIN for modifications of the settings
- ▶ Receiver can be boosted
- ▶ Connector for secondary call bell

Application

The telephone **TAS27** is as stylish for indoor use as it is resistant for outdoor use in areas without explosive atmospheres.

The **TAS27** is the ideal telephone for many different work areas seawater, high air humidity, dust and not exactly gentle mechanical stress are no problem for it.

Through the protection-door, the handset and keypad are always perfectly protected against contaminations.

Its striking signal colour ensure the **TAS27** cannot be missed whenever a telephone is urgently needed.



The TAS27 the ideal telephone
for many differential work areas.



Technical specifications

Supply voltage.....	24 ... 66 Vdc
Supply current.....	19 ... 100 mA
Ringng alternating current	30 ... 90 Vac
Ringng frequency.....	16 ... 68 Hz
Sounder input impedance	≥6.0 kohm at 25 Hz ≥3.5 kohm at 50 Hz
Enquiry key (flash)	only for DTMF 80 ms,120 ms,600 ms
Dialling procedure	
DTMF.....	Frequencies according to ITU-T Q.23 Tone duration unlimited or 90 ms
PD.....	Pulse/Pause ratio 1.5:1 (60/40 ms)or 2:1 (66.7/33.3 ms)
Ringng volume housing cover:	
open.....	Approx.90 dB(A)at 1 m distance
closed.....	Approx.65 dB(A)at 1 m distance
Secondary telephone bell connector	
Housing	Polycarbonate
Height x Width x Depth	330 x 237 x 110 mm
Weight.....	2.3 kg (Telephone incl.telephone bracket)
Operating utilization position.....	Vertical wall mounting
Receiver:	
Mouthpiece	electret-foil microphone
Receiver inset.....	dynamic receiver
Connections	single-or multiwired up to 2.5 mm ²
Labelling:	
Power cable	TCP/La – TCP//Lb (TCP:Terminal Connection Point)
Ambient operating temp.	-25 °C ...+55 °C
Transport and storage temp.	-25 °C ...+70 °C
Degree of protection acc.to IEC60529	IP 66 (closed door)
Cable gland	2x M16 x 1.5
for cable diameters.....	5 - 9 mm

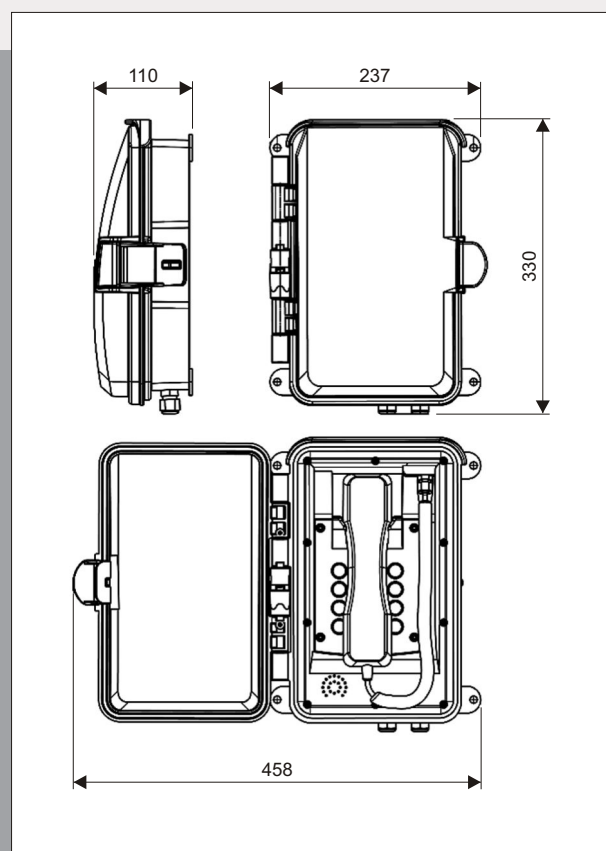

Designation	Type	Article
Weatherproof telephone set	TAS27	7132127