

FITRE S.p.A. • Divisione DSI

20142 Milano • Italia • via Valsolda, 15
telefono: (+39) 02.8959.01 • telefax: (+39) 02.8959.0400
e-mail: info@fitre.it

Analogue desk/wall telephone for indoor and outdoor use

- ▶ Housing: Polycarbonate
- ▶ Protection degree: IP 65
- ▶ Call tone: approx.95 dB(A)
- ▶ Temperature range: -25°C up to +55°C
- ▶ Option: Display
- ▶ Option: Steel arm.handset cord

Application

The **TAS 26** telephone from **FITRE** is as stylish for indoor use as it is resistant for outdoor use in areas without explosive atmospheres. Its modern design is the perfect "packing" for the finest high-tech.

Its striking signal colours ensure the **TAS 26** cannot be missed whenever a telephone is urgently needed, e.g. in emergencies in poor weather and light conditions.

The **TAS 26** is suitable for almost universal use thanks to its amazing transformability.

A deft hand movement and the desk telephone for indoor use is converted into a wall telephone for outside use.

Equipped with 16 or 21 keys, freely programmable and functionally reliable in every weather, the new **TAS 26** is the ideal telephone for many different work areas seawater, high air humidity, dust and not exactly gentle mechanical stress are no problem for it.

The stylish housing is made of impactresistant and shockproof plastic moulding.

Even acids, alkalis or lubricants cannot damage the high-quality components of our new versatile desk/wall telephone.

**Use as workshop telephone**

The **TAS 26** is the ideal telephone for many different work areas.



Technical specifications

Connection data

Supply voltage	24....66 Vdc
Supply current	19....100 mA
Ringing alternating current	30....90 Vac
Ringing frequency	16....68 Hz
Sounder input impedance	≥ 6.0 kohm at 25 Hz ≥ 3.5 kohm at 50 Hz
Enquiry key (flash)	only for DTMF 80 ms, 120 ms, 600 ms
Dialling procedure	
DTMF	Frequencies according to ITU-T Q.23 Tone duration unlimited or 90 ms
PD	Pulse/Pause ratio 1.5:1 (60/40 ms) or 2:1 (66.7/33.3 ms)
Ringing volume	Approx. 95 dB(A) at 1 m distance

Housing

Height x Width x Depth	128 x 190 x 291 mm
Weight	Approx. 1.7 kg
Display	2 lines, 16 positions per row, 7x 5 matrix Pictograms
Operating utilization position	Table or vertical wall mounting

Receiver

Mouthpiece	Electret-foil microphone
Receiver inset	dynamic receiver inset with magnetic field generator

Connections Single - or multiwired up to 2.5 mm²

Labelling

Power cable	TCP / TCP (Terminal Connection Point)
Secondary sounder	W / W1

Environmental conditions	without LCD	with LCD
Ambient operating temp.	-25°C...+55°C	-10°C...+50°C
Transport and storage temp.	-25°C...+70°C	-20°C...+60°C
Degree of protection acc. to IEC60529		IP 65

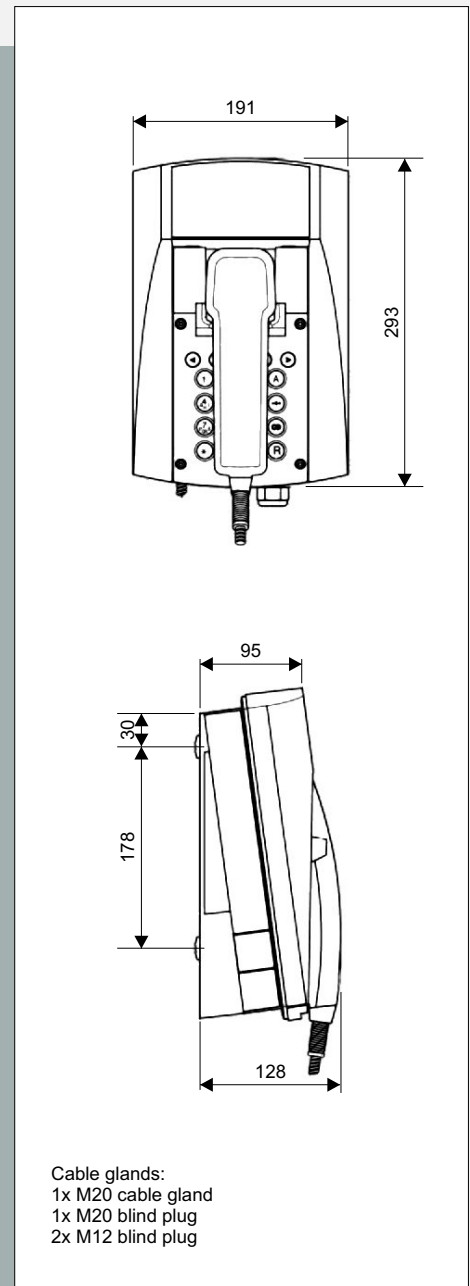

Designation	Type	Article
Weatherproof telephone set without display	TAS26	7137120
Weatherproof telephone set with display	TAS26D	7137121