

Sound-powered phones for emergency communications
P/N 8311103

Weatherproof sound-powered telephone

- Polyamide body
- Outgoing calling sound-wheel equipped

Available accessories:

- Jack Plug - P/N 2964156 • Socket - P/N 2964088
- Clamp TS105 - P/N 8319825 • Cable TS104 - P/N 8319826
- Carrying bag G/320A - P/N 8319812

HANDSET

-- NOTE --

In order to connect a call repeater (for instance a R140 Rainbow) to the G2100 telephone, it is necessary to insert a 2.2 μ F-50V non-polarized polyester capacitor (P/N 2242007) inside the junction box (out of Fitre's scope of supply), as reported on the block diagram here below.

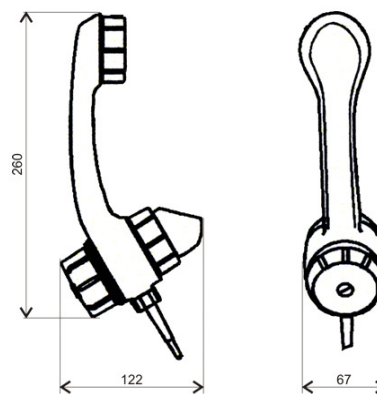
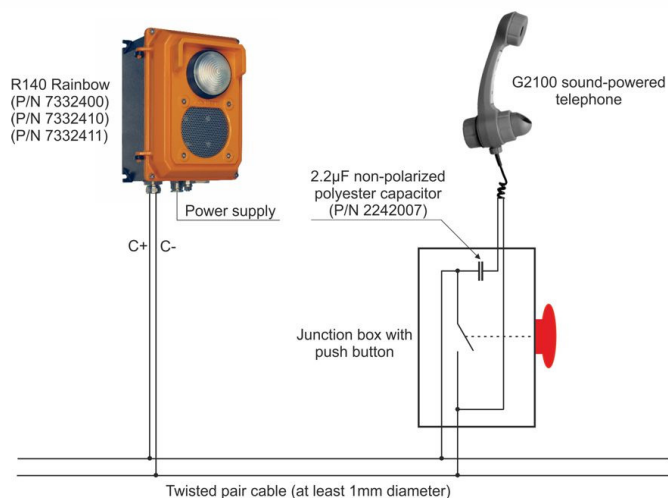
dimensions (W x H x D) 67,0 x 260,0 x 122,0 mm
weight 600 g
