

FITRE S.p.A. • Divisione DSI

20142 Milano • Italia • via Valsolda, 15
 telefono: (+39) 02.8959.01 • telefax: (+39) 02.8959.0400
 e-mail: divisione.dsi@fitre.it

Acoustic hood with a transparent metacrylate dome while the backside is made of a special sound absorbent plastic, suitable for indoor and outdoor installation

General purpose model, with pre-perforated back plate for installing telephones and weatherproof / explosion proof Intercom phones manufactured by Fitre.

Ready for wall or column mounting

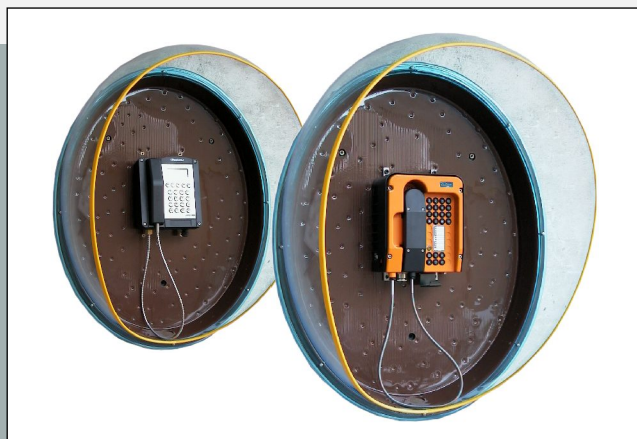

Support Column, standard height of 1850 mm, in zincated steel or zincated and RAL7031 paint, with a concrete base, setup with fasteners for fixing the acoustic hood P83.

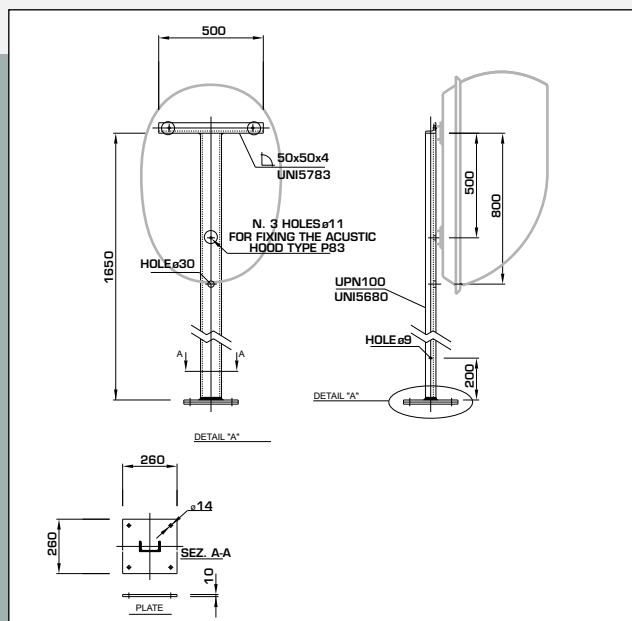
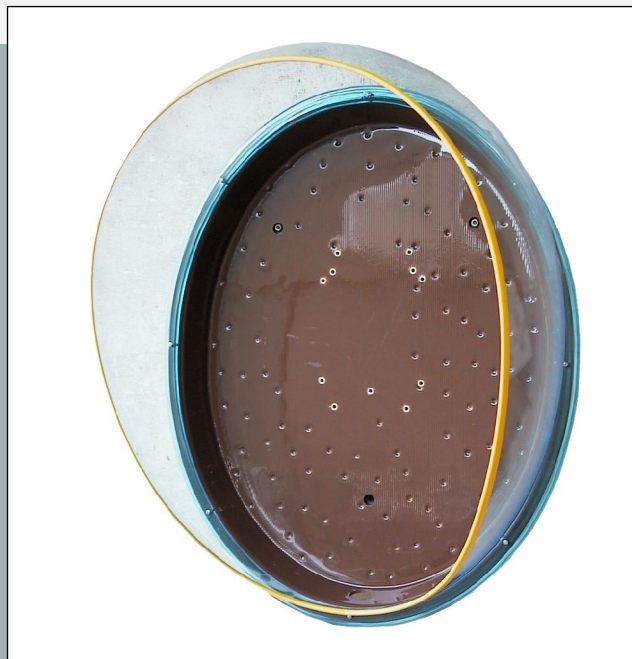
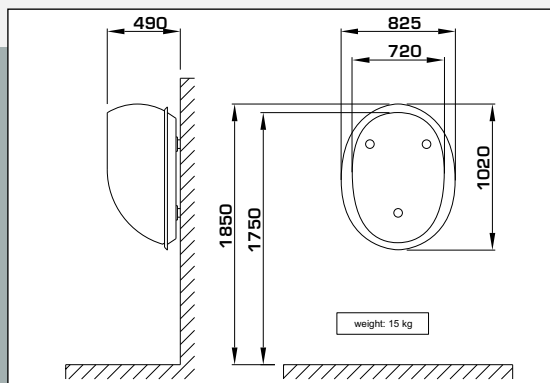

Description	Type	Code
• Acoustic hood in polycarbonate ready for TAS2000 / IF2000 / TAS22AD	P83	5617124
• Column height 1850 mm, zincated		5617153
• Column height 1850 mm, zincated and painted		5617152