

**Indoor, weatherproof and explosion-proof phones (analog & VoIP)**
**P/N 7137121**

Weatherproof analog ACB telephone with display for indoor and outdoor use.

The TAS26D telephone is as stylish for indoor use as it is resistant for outdoor use in areas without explosive atmospheres. Its modern design is the perfect "packing" for the finest high-tech and its striking signal colours ensure that TAS26D cannot be missed whenever a telephone is urgently needed, e.g. in case of an emergency in poor weather and light conditions.

The TAS26D is suitable for almost universal use thanks to its amazing transformability. A deft hand movement and the desk telephone for indoor use is converted into a wall telephone for outside use.

The stylish housing is made of impact-resistant and shockproof plastic moulding.

Even acids, alkalis or lubricants cannot damage the high-quality components of our new versatile desk/wall telephone.

- Sturdy and impact-resistant polycarbonate case
- Shock-resistant
- Chemical-resistant
- IP65 protection
- Full 12-key keyboard
- PIN code
- Display with 2 lines, 16 positions per row, 7x5 matrix pictograms, 4 languages
- Ringing volume:  $\geq 95$ dB(A) at 1m distance
- Supply voltage: 24÷66VDC
- Supply current: 19÷100mA
- Ringing alternating current: 19÷68Hz
- Ringing frequency: 18÷68Hz
- Mouthpiece: electret-foil microphone
- Yellow, red, grey or black colour
- Shock-resistant
- Chemical-resistant
- Lockable handset with stabilization bracket (option)
- Cable glands: 1x M20 cable gland, 1x M20 blind plug, 2x M12 blind plugs

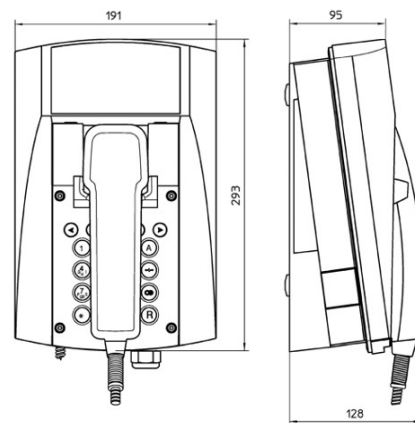
**HANDSET**
**DESK/WALL MOUNTING**
**IP65**
**- 25°C to + 55°C**

**dimensions (W x H x D) 191,0 x 293,0 x 128,0 mm**
**weight 1,7 kg**
